

Basic Requirements (15):
 Chem (1.34) Math (4)
 Physics (2.68) EA (4)
 Speaking (1) DTC (2)

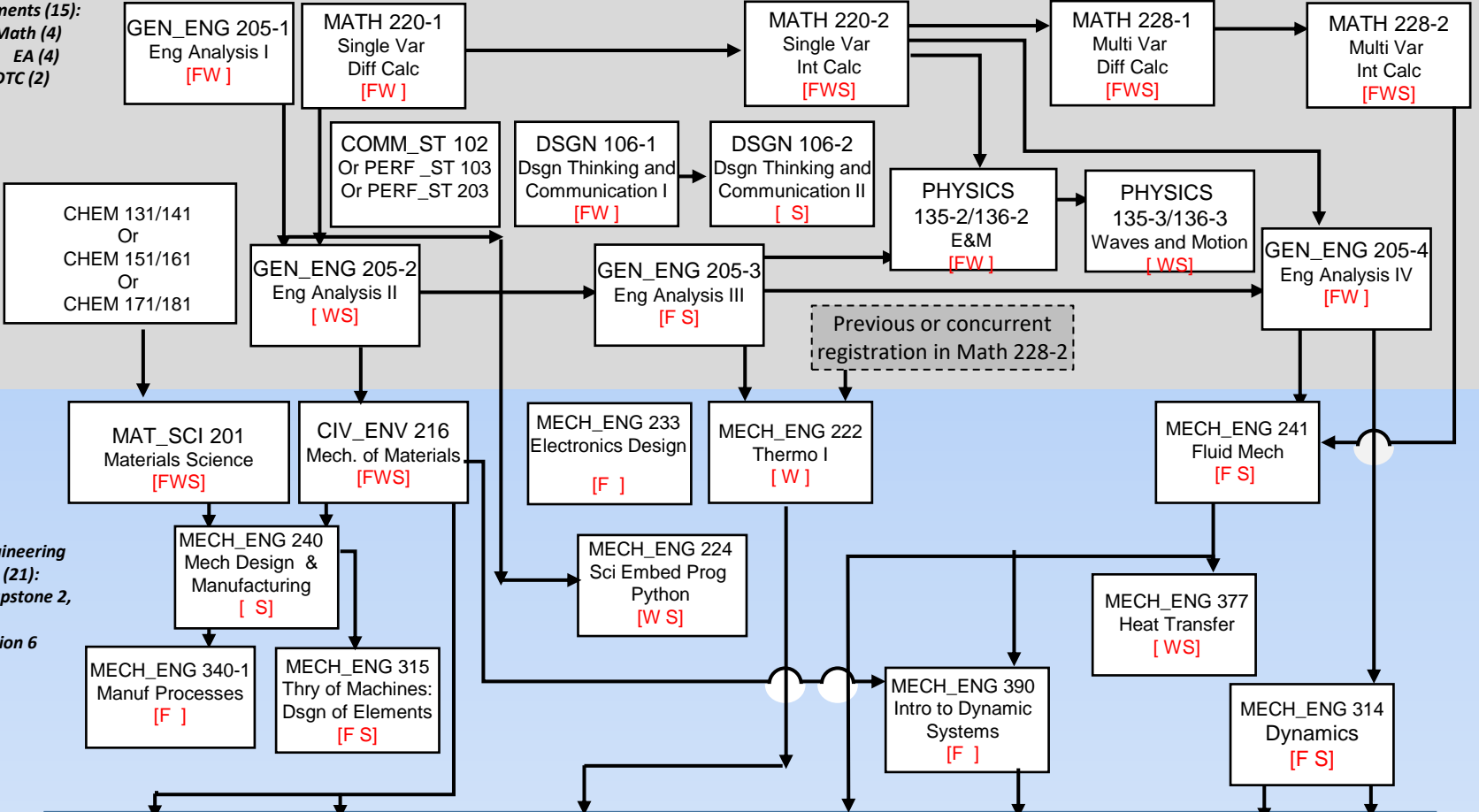

**Mechanical Engineering
 Major Program (21):**
 Required 12, Capstone 2,
 Math/Sci 1,
 and Concentration 6

Any 300-level course in basic mathematics or science, or COMP_SCI 212 or CHEM 215, or a course recommended as part of the chosen concentration and must choose one of the Concentrations for a total of 7 units: ME Breadth, Aerospace Engineering, Design, Energy Systems and Sustainability, Manufacturing, Mechanical Sciences, Robotics

Must be taken consecutively, within three quarters of graduation

MECH_ENG 398-1
Engineering Dsgn
[FW]

MECH_ENG 398-2
Engineering Dsgn
[WS]

Theme Requirements (7)							Unrestricted Electives (5)					Instructions: Cross out classes that you have taken. Circle the concentration in the above list that you are following.
Refer to Undergraduate Curriculum on the ME Website												